

0636

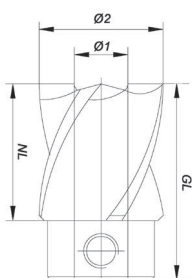

AUFSTECK-STUFENSENKER
ADJUSTABLE COUNTERBORE
FRAISE À FOND PLAT

DE Ausführung: 2 Schneiden, 2 Vorschneider.

Verwendung: Zum Planversenken in Weich- und Hartholz, sowie Kunststoffen mit unseren Spiralbohrern 011, 012 und 013.
Drehzahl: 2000-4000 U/min.

EN Characteristics: 2 cutters and 2 spurs. Please specify all necessary measurements.

Usage: For countersinking in soft- and hardwoods, with our wood twist drills No. 011, 012 and 013.
2000-4000 RPM.

FR Caractéristiques: En acier rapide HSS, 2 coupes, 2 traçoirs.

Utilisation: Outil indispensable pour les charpentiers, il permet de noyer les têtes de boulons et les rondelles dans les bois durs et tendres en une seule opération.
Vitesse de rotation: 2000-4000 t/min.

Ø1	Ø2	NL	GL	EAN	ART.NR.
5	13	13	22	9002696115311	0636050130
5	14	13	22	9002696269526	0636050140
5	15	15	22	9002696115328	0636050150
6	13	13	22	9002696268246	0636060130
6	15	13	22	9002696048275	0636060150
8	16	16	25	9002696115427	0636080160
8	20	16	25	9002696048282	0636080200
8	25	16	25	9002696048299	0636080250
10	20	16	25	9002696115465	0636100200
10	25	16	25	9002696048305	0636100250
10	30	16	25	9002696115472	0636100300
12	25	16	25	9002696055518	0636120250
12	30	18	28	9002696138204	0636120300
12	35	20	32	9002696115533	0636120350
12	40	20	32	9002696170723	0636120400
12	45	25	38	9002696115540	0636120450
14	45	25	38	9002696115595	0636140450
14	50	25	38	9002696115601	0636140500

063H

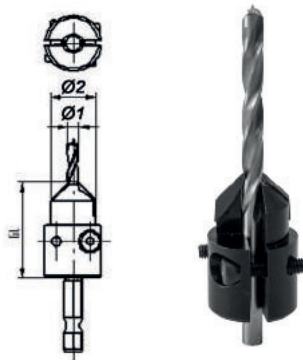

HW AUFSTECKVERSENKER, VERSTELLBAR
TCT ADJUSTABLE COUNTERSINK
FRAISE CARBURE REGLABLE

DE Ausführung: HW-bestückt, 90°, 2 Klemmschrauben mit Innensechskant.

Verwendung: Mit unseren Holzspiralbohrern von 3-8 mm. Zum Bohren und Ansenken in einem Arbeitsgang.
Drehzahlen: 1500-3500 U/min.

EN Characteristics: TCT, 90°.

Usage: To be used with our Wood Twist Drills from 3 to 8 mm. For drilling and countersinking in a single operation.
1500-3500 RPM.

FR Caractéristiques: En 2 parties, avec plaquettes au carbure, angle de 90°. Réglable de 3 à 8 mm.

Utilisation: Permet de fraiser en une seule passe l'emplacement de la tête de vis.
Vitesse de rotation: 1500-3500 t/min.

Ø1	Ø2	GL	EAN	ART.NR.
3-8	16-22	35	9002696016113	063H MV3-8